



COMMERCIAL VEHICLE AUCTIONS LTD
THE UK'S MOST ESTABLISHED COMMERCIAL VEHICLE AUCTIONEERS

Carr Hill Industrial Estate
Doncaster
DN4 8DE

01302 732600 | cva.noreply@cva-auctions.co.uk

VEHICLE INSPECTION REPORT

KP19SNB

Mercedes-Benz Sprinter 314 CDI

Inspection		Vehicle	
Serious Damage?	No	VAT	Plus VAT
		V5	Present

Details			
Reg. date	29/08/2019	Colour	WHITE
Year	2019	VIN	WDB9076332P131328
Mileage	147,038 Miles Not Warranted	Body Style	Panel Van L2
Fuel Type	Diesel	MOT Due	28/10/2026
GVW	3500kg	CAP Clean	£8,375.00
		CAP Average	£7,200.00
		CAP Below	£5,625.00
		Gearbox	MANUAL
		Gears	6

WARNING LIGHTS ON DASH AD BLUE, SIDE LOADING DOOR

Tyres
NSF
NSR
OSF
OSR
Spare

Features

- Rear parking sensor
- Front electric windows

Photos



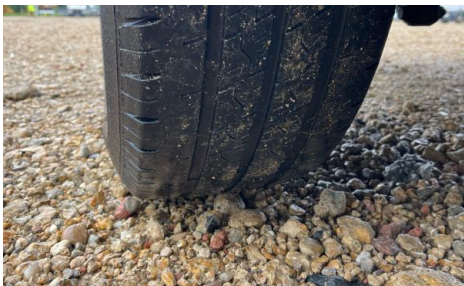
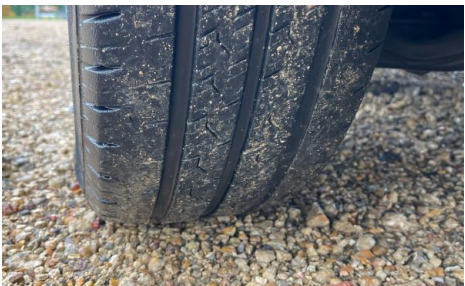

Condition Check

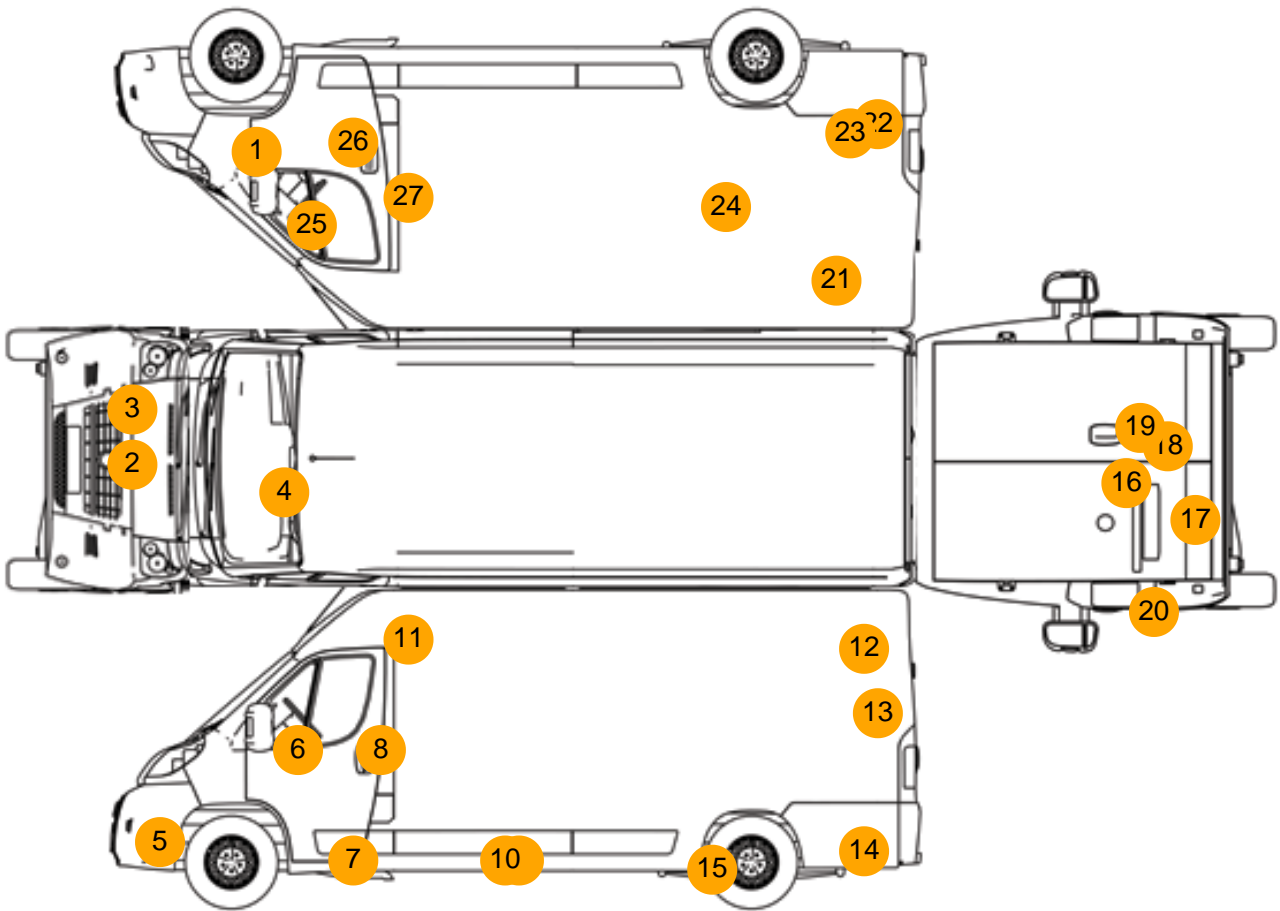

Damage Photos



1: Wing Front Arch Extension os
Missing
Replace



2: Bumper Front
Insecure
Action Required



3: Bumper Front
Insecure
Action Required



4: Screen Front
Chipped
Over 10mm



5: Bumper Front Moulding
Scuffed (Unpainted)
Over 100mm

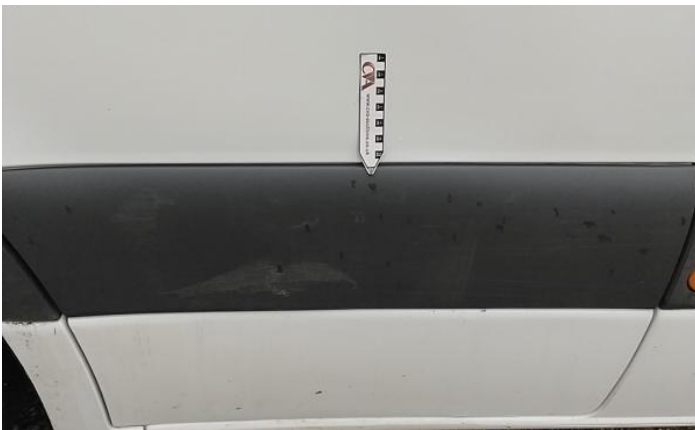

6: Door Mirror Assy nsf
Scuffed (Unpainted)
Over 100mm



7: Door Moulding nsf
Scuffed (Unpainted)
Over 100mm

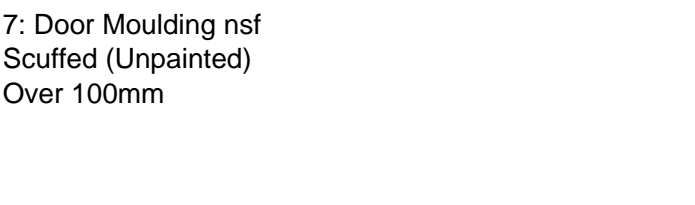

8: Door nsf
Scratched
Over 25mm Not Thru Paint

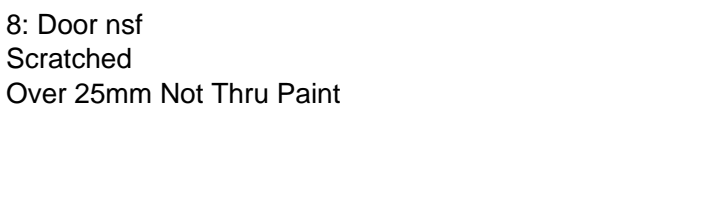



9: Door Moulding nsr
Scuffed (Unpainted)
Over 100mm



10: Door nsr
Dented
With Paint Damage



11: Roof
Dented
With Paint Damage



12: Roof
Dented
With Paint Damage



13: Qtr Panel nsr
Scratched
Over 25mm Not Thru Paint



14: Qtr Panel Moulding ns
Scuffed (Unpainted)
Over 100mm



15: Qtr Panel Moulding ns
Scuffed (Unpainted)
Over 100mm

16: Badgedecal Rear
Broken
Replace



17: Door nsr
Dented
With Paint Damage

18: Door osr
Dented
With Paint Damage



19: Door osr
Scratched
Over 25mm Thru Paint

20: Lamp nsr
Broken
Replace

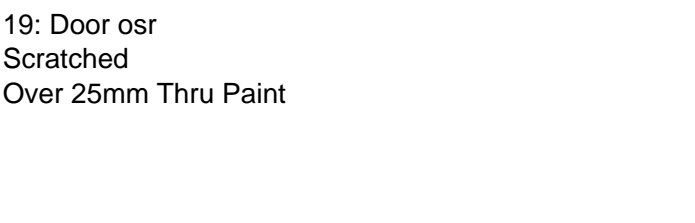



21: Qtr Panel osr
Scratched
Over 25mm Not Thru Paint

22: Qtr Panel Trim os
Scuffed
Over 25mm



23: Qtr Panel osr
Dented
With Paint Damage

24: Qtr Panel osr
Scratched
Over 25mm Thru Paint



25: Door Mirror Assy osf
Scuffed (Unpainted)
UpTo 100mm

26: Door osf
Scratched
Over 25mm Thru Paint



27: Door osf
 Scratched
 Over 25mm Not Thru Paint

28: Seat Base Cover osf
 Holed
 Over 3mm



29: Steering Wheel
 Damaged
 Replace

Interior

Carpet Condition	Average	Upholstery Condition	Average
Seat Condition	Average	Odour	No
Engine Runs	OK	Gearbox 1st and Reverse Test	OK
Brakes	OK	Clutch Slip Test from Static	OK
Parking Brake	OK	Gearbox Static Gear Selection (engine running)	OK
		No Excessive Smoking	OK
EML light illuminated	Fault	Oil warning light illuminated	OK
Airbag light illuminated	Fault	DPF light illuminated	OK
ABS light illuminated	Fault	Service indicator light illuminated	Fault